

JULY
2010

 Fenner Drives®



T-Max®
BELT & CHAIN TENSIONERS



Why Should I Use a T-MAX Tensioner?

Why Should I Use a Tensioner? 2

How to Select a Tensioner..... 3

T-Max Light-Duty Rotary Tensioners..... 4

 RT1000 5

 RT1600 5

T-Max Medium- and Heavy-Duty Rotary Tensioners..... 6

 RT3000 7

 RT4100 8

 RT4900 9

T-Max Linear Tensioners..... 10

 CT1100, CT2100, CT3100 11

 CT1200, CT2200, CT3200 12

 CT1400, CT2400, CT3400 Fixed 13

 LT1000, LT2000, LT3000 14

T-Max Tensioner Selection Chart for Roller Chain Drives..... 15

PowerMax™ Idler Pulleys and Sprockets 16

Overhung Load Information 17

Application Examples..... 18

Frequently Asked Questions..... 19

To achieve optimum drive performance, correct drive belt or chain tension must be maintained. A self-adjusting T-Max Tensioner from Fenner Drives is the solution. Available in both rotary and linear designs, T-Max automatic tensioners eliminate the need for regular manual retensioning of drives. The risk of inadvertently over-tensioning drive components is avoided and overall drive operating efficiency is enhanced.

All frictional V- and flat belt and roller chain drives elongate over time through use and wear. A properly designed and installed V-belt drive typically will offer an efficiency rating of 96%. Left unattended, the V-belt will elongate, allowing slippage to occur. This generates heat, which adversely affects belt life, accelerates pulley groove wear and can reduce drive efficiency by as much as 10%. In addition to energy waste, incorrect belt tension leads to increased drive downtime and higher operating costs, as well as inflated replacement costs due to premature belt failure.

T-Max Tensioners work by applying a preset load to the V-belt or chain which yields the proper tension for optimum efficiency and life. As the V-belt stretches or the chain wears, the spring-loaded tensioner automatically takes up the slack, saving energy, decreasing downtime, and reducing operating costs.

Most of the above information also applies to roller chain drives, except that due to the more positive drive characteristics of chain, efficiency losses are approximately 3%.

Combined with a PowerMax idler pulley or chain sprocket from Fenner Drives, an automatic T-Max Tensioner can be used to:

- Maintain correct belt and chain drive tension
- Extend the life of critical drive components
- Reduce system downtime
- Increase drive and energy efficiency
- Reduce belt and chain whip on long center drives
- Ensure drive components do not snag obstructions
- Reduce resonant frequency of chain drives



North American Sales Office
1-800-243-3374
1-717-665-2421

European Sales Office
+44(0) 870 7577007
+44(0) 113 2493486

www.fennerdrives.com

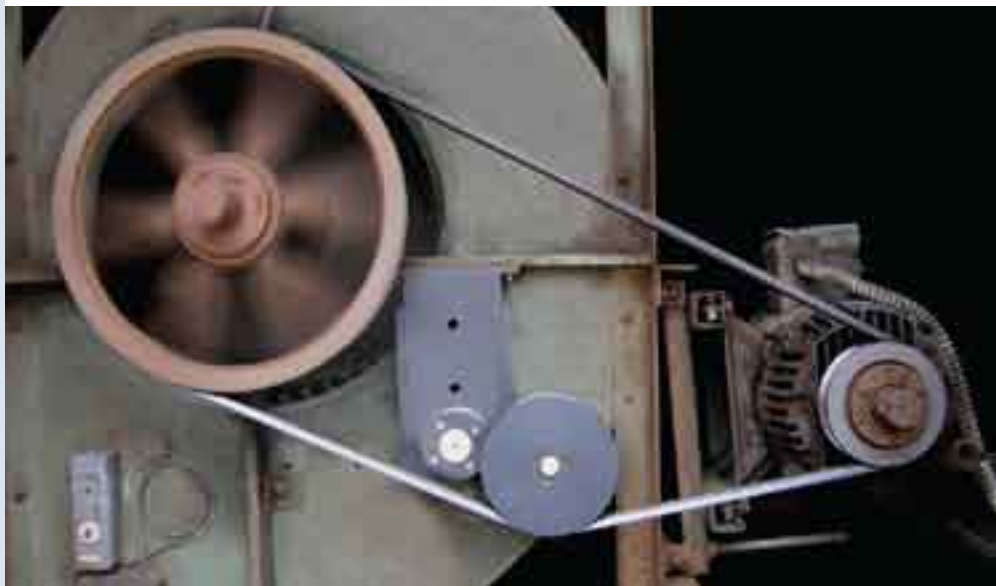

How to Select a **T-MAX** Tensioner

Selecting a tensioner can be difficult because there is no cut-and-dried method for determining the amount of force a tensioner should develop. The size and type of tensioner (belt or chain) are determined based on knowing the drive parameters and power requirements, speed, torque, cycles, etc. These guidelines are suggestions to assist the designer. If there is any doubt, spring force determination should be made in consultation with the belt or chain manufacturer.

V-belt Drives – Light-Duty

The RT1000 and RT1600 series are best suited for single groove V-belt drives using 3L, SPZ, A/13 (4L) or B/17 (5L) belts. They also can be used with the J and K section Micro-V belts.

V-belt Drives – Medium-Duty

The RT3000 series is best suited for single or double groove V-belt drives using A/13 (4L), SPA, B/17 (5L), SPB or 3V and 5V narrow wedge belts. It can also be used with the J, K and M section Micro-V belts.

V-belt Drives – Heavy-Duty

RT4100 and RT4900 series tensioners are designed for use on drives with two to four B/17, SPB or 5V narrow wedge belts, one to two C/22 or SPC cross-section belts or multiple groove K and M Micro-V belts.

Chain Drives

Refer to the selection chart on page 15.

Synchronous Belt Drives

Automatic tensioners are not usually used on power transmitting synchronous belt drives, but are acceptable for use on drives strictly for motion transfer. If an automatic tensioner is desired for a power transmitting drive, consult the belt manufacturer for recommendations.

Idler Guidelines

- Always mount idler on the slack side of the drive, with preferred mounting on the inside of the slack side.
- Follow the belt manufacturer's recommended minimum idler diameter.
- Optimum location for the tensioner is where the idler provides nearly equal arcs of contact on both the driveR and driveN pulleys or sprockets.
- Keep overhung load to a minimum. (See page 17)
- For assistance, contact Fenner Drives Applications Engineering group at 1-800-243-3374 or email ae@fennerdrives.com.



Light-Duty Rotary Tensioners

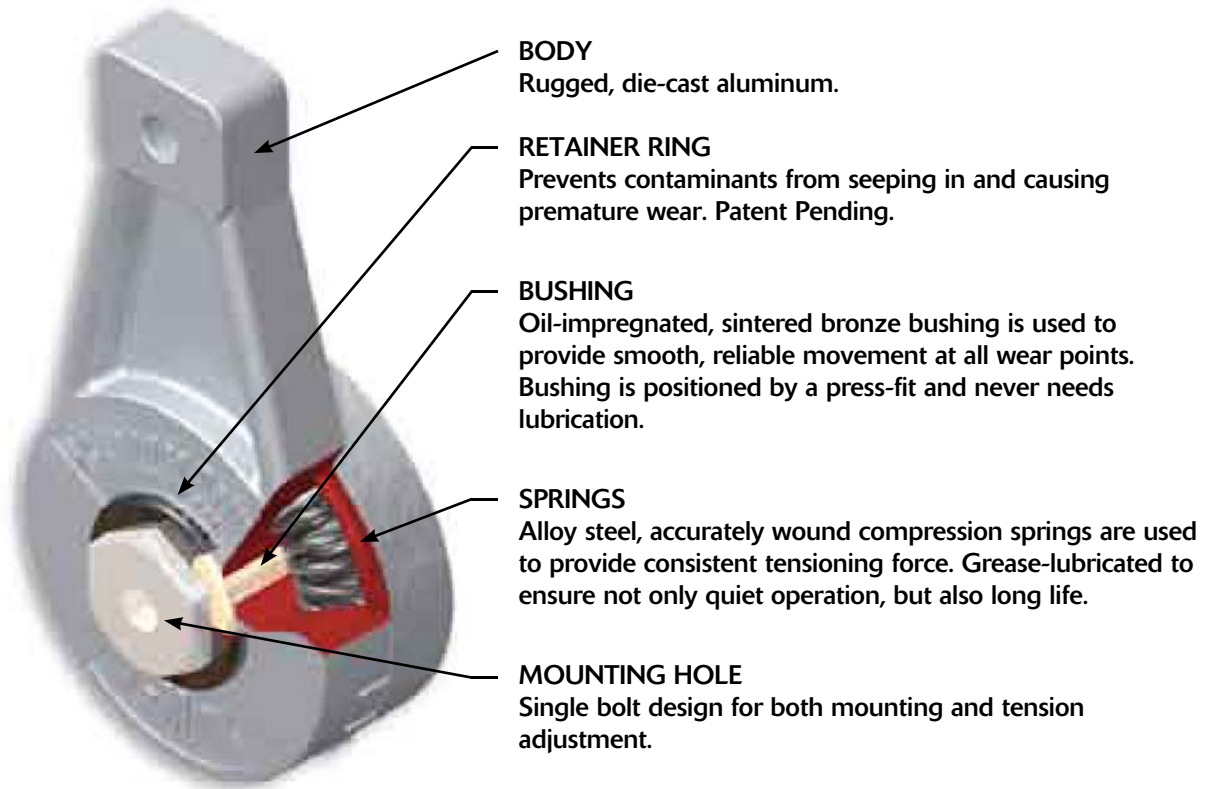

- Rugged, heavy-duty construction
- Easy installation and adjustment with single bolt feature
- Wide variety of sizes and mounting styles
- Improved performance and extended life for most fixed-center drives
- Built-in spring mechanism absorbs momentary overloads and reduces vibration
- Constructed from high-quality materials for proven durability
- Graduated scale tension adjustment
- Not to be used on reciprocating drives
- For harsh environments, contact Applications Engineering
- Ideal for use with PowerMax™ Idler Pulleys and Sprockets

RT1000 Series

- Die-cast aluminum construction
- Spring forces up to 30 lbs.
- Do not use on reciprocating applications such as IC engines and piston devices

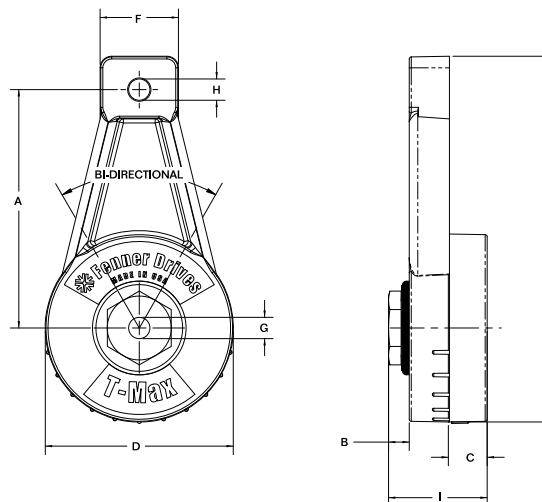

Part No.	A	B	C	D	E	F	G	H	I	Rotation (degrees)	Force ⁽²⁾ (lbs.)
RT1001	3.50	0.29	0.59	2.76	5.37	1.15	3/8-16	3/8-16	1.45	15	16
										30	23
										45	30
RT1003	3.50	0.29	0.59	2.76	5.37	1.15	0.40	3/8-16	1.45	15	16
										30	23
										45	30

RT1600 Series

- Die-cast aluminum construction
- Extended arm length
- Spring forces up to 26 lbs.
- Do not use on reciprocating applications such as IC engines and piston devices

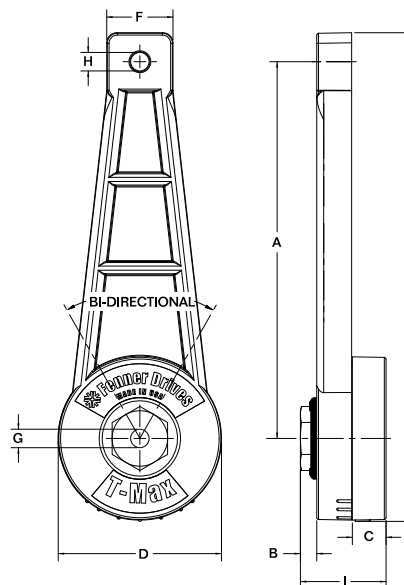

Part No.	A	B	C	D	E	F	G	H	I	Rotation (degrees)	Force ⁽²⁾ (lbs.)
RT1601-L	6.37	0.29	0.59	2.75	8.24	1.12	3/8-16	3/8-16	1.45	15	10
										30	13
										45	16
RT1603-L	6.37	0.29	0.59	2.75	8.24	1.12	0.40	3/8-16	1.45	15	10
										30	13
										45	16
RT1601	6.37	0.29	0.59	2.75	8.24	1.12	3/8-16	3/8-16	1.45	15	20
										25	23
										35	26
RT1603	6.37	0.29	0.59	2.75	8.24	1.12	0.40	3/8-16	1.45	15	20
										25	23
										35	26

Notes 1) All dimensions are in inches.

2) All forces (lbs.) are nominal.

3) Maximum load no more than 1" distance from front face of tensioner to centerline of idler — see page 17.

Medium- & Heavy-Duty Rotary Tensioners

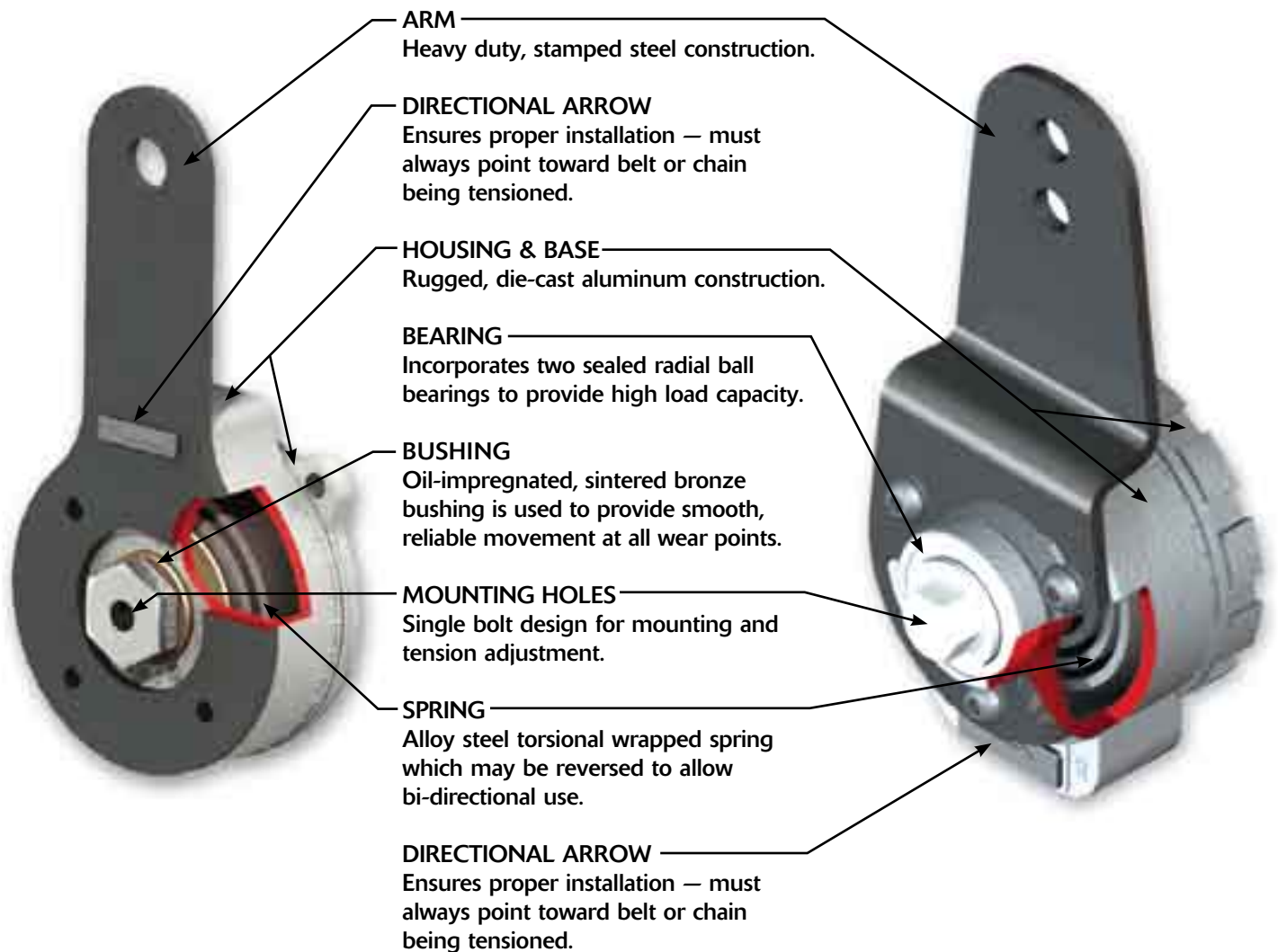

- The industry's first medium- and heavy-duty tensioners for multiple belts
- Rugged, heavy-duty construction for heavy load applications
- Designed for use with single or multiple belts or strands of chain
- Arms available in custom lengths for optimum idler positioning
- No elastomeric tension members to cold-flow, fatigue or take a compression set
- Torsion spring absorbs momentary overloads and reduces vibration
- Ideal for use with single or multiple groove V- and flat belt idler pulleys, available from Fenner Drives
- For harsh environments, contact Applications Engineering

RT3000 Series

- Heavy duty stamped steel arm
- Die-cast aluminum construction
- Spring forces up to 42 lbs.
- Suitable for use on reciprocating applications such as IC engines and piston devices

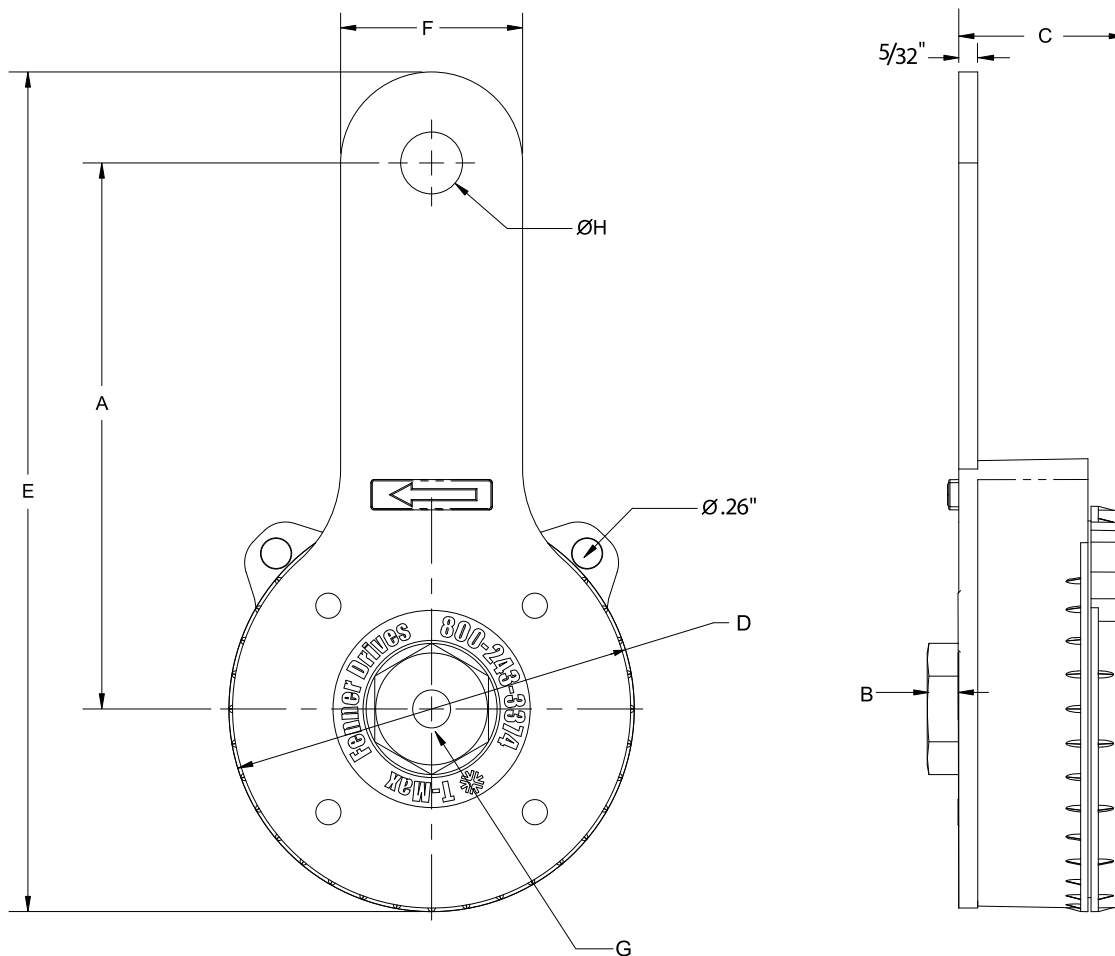

Part No.	A	B	C	D	E	F	G	H	Rotation ⁽³⁾ (degrees)	Force ⁽³⁾ (lbs.)
RT3000	4.50	0.26	1.37	3.34	6.92	1.50	$\frac{3}{8}$ -16	0.51	0 - 70	0 - 42
RT3001	4.50	0.26	1.37	3.34	6.92	1.50	0.40	0.51	0 - 70	0 - 42

- Notes
- 1) All dimensions are in inches.
 - 2) Maximum load no more than 1 1/2" distance from front face of tensioner arm to centerline of idler — see page 17.
 - 3) 1° rotation = .6 lb. force. All forces (lbs.) are nominal.
 - 4) RT3000 and RT3001 Patents Pending

RT4100 Series

- Heavy duty stamped steel arm
- Die-cast aluminum construction
- Spring forces up to 85 lbs.
- Suitable for use on reciprocating applications such as IC engines and piston devices

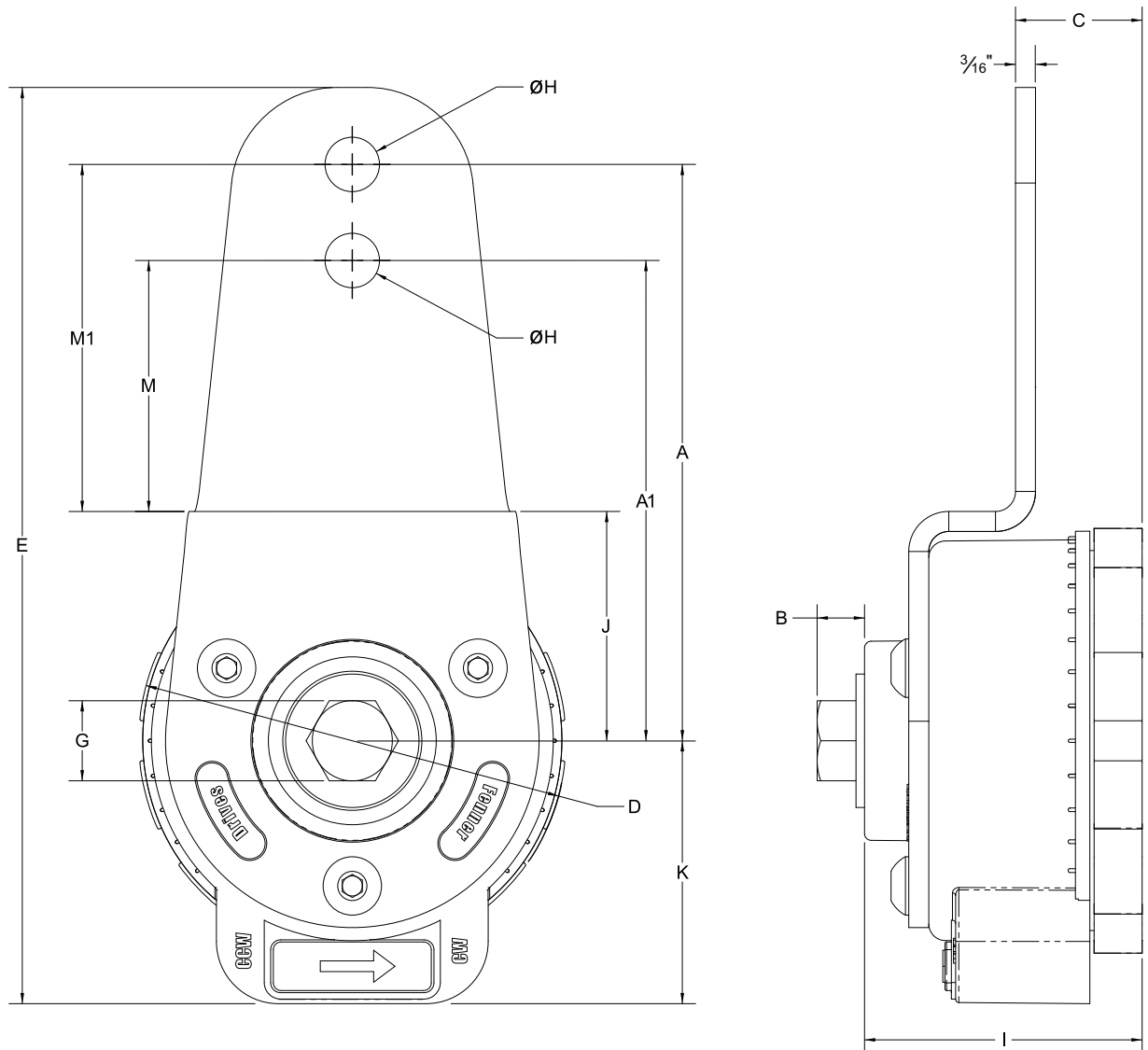

Part No.	A	A1	B	C	D	E	G	H	I	J	K	M	M1	Rotation ⁽³⁾ (degrees)	Force ⁽³⁾ (lbs.)
RT4100	5.40	4.50	0.49	1.19	4.00	8.58	½-13	0.51	2.60	2.15	2.46	2.35	3.25	0 - 85	0 - 85
RT4101	5.40	4.50	N/A	1.19	4.00	8.58	0.51	0.51	2.60	2.15	2.46	2.35	3.25	0 - 85	0 - 85

- Notes
- 1) All dimensions are in inches.
 - 2) Maximum load no more than 1 ½" distance from front face of tensioner arm to centerline of idler — see page 17.
 - 3) Dimension A: 1° rotation = .83 lb. force.
Dimension A1: 1° rotation = 1 lb. force. All forces (lbs.) are nominal.
 - 4) Requires a fixed head, hook style spanner wrench for tensioning (supplied with unit).
 - 5) U.S. Patent Numbers 6,855,079 and 6,855,079 B2

RT4900 Series

- Heavy duty laser-cut steel arm
- Straight arm allows alternative mounting
- Die-cast aluminum construction
- Spring forces up to 70 lbs.
- Suitable for use on reciprocating applications such as IC engines and piston devices.

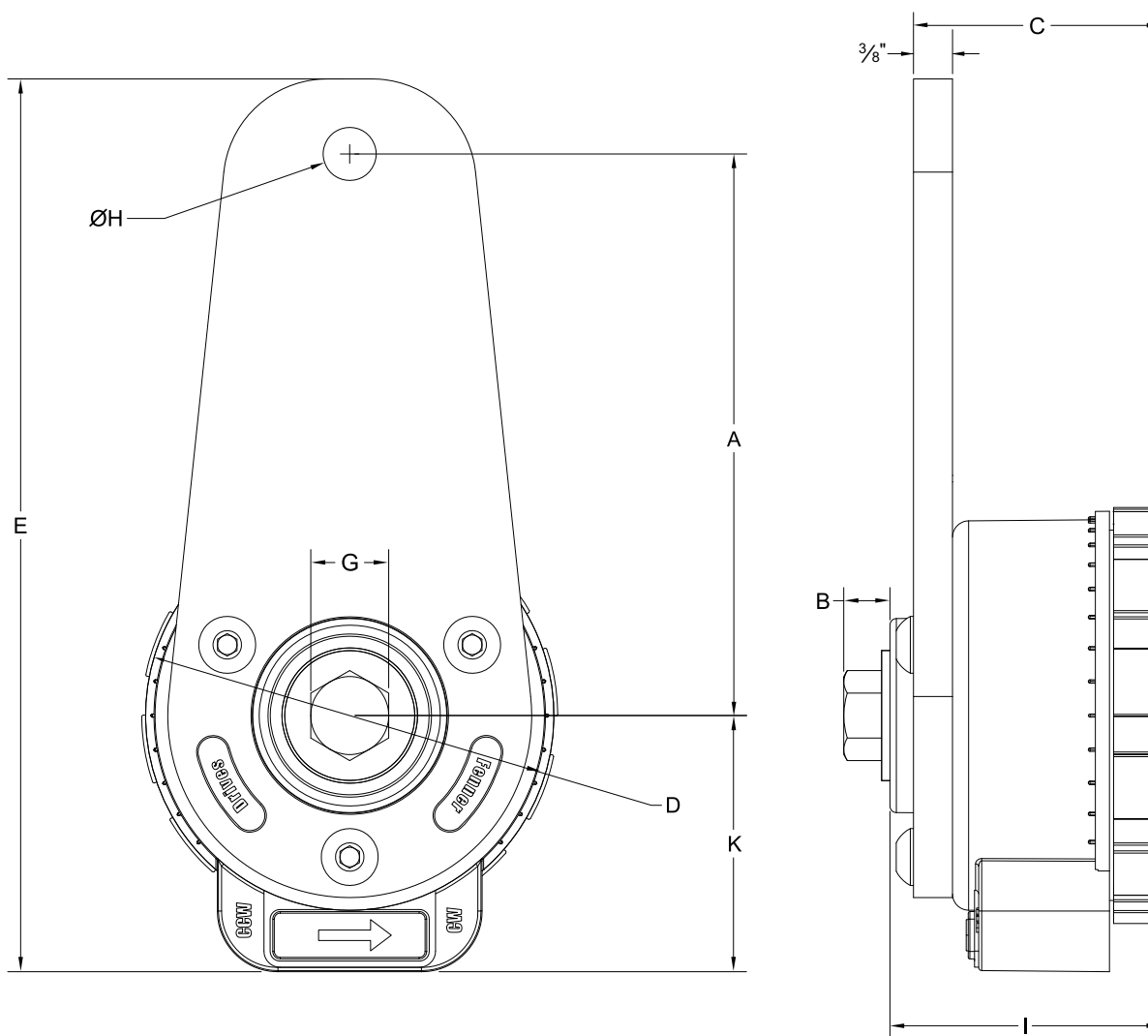

Part No.	A	B	C	D	E	G	H	I	K	Rotation ⁽³⁾ (degrees)	Force ⁽³⁾ (lbs.)
RT4900	5.40	N/A	2.37	4.00	8.58	0.51	0.51	2.60	2.46	0 - 85	0 - 70
RT4902	5.40	0.49	2.37	4.00	8.58	½-13	0.51	2.60	2.46	0 - 85	0 - 70

- Notes
- 1) All dimensions are in inches.
 - 2) Maximum load no more than 1½" distance from front face of tensioner arm to centerline of idler — see page 17.
 - 3) 1° rotation = .83 lb. force. All forces (lbs.) are nominal.
 - 4) Requires a fixed head, hook style spanner wrench for tensioning (supplied with unit).
 - 5) U.S. Patent Numbers 6,855,079 and 6,855,079 B2

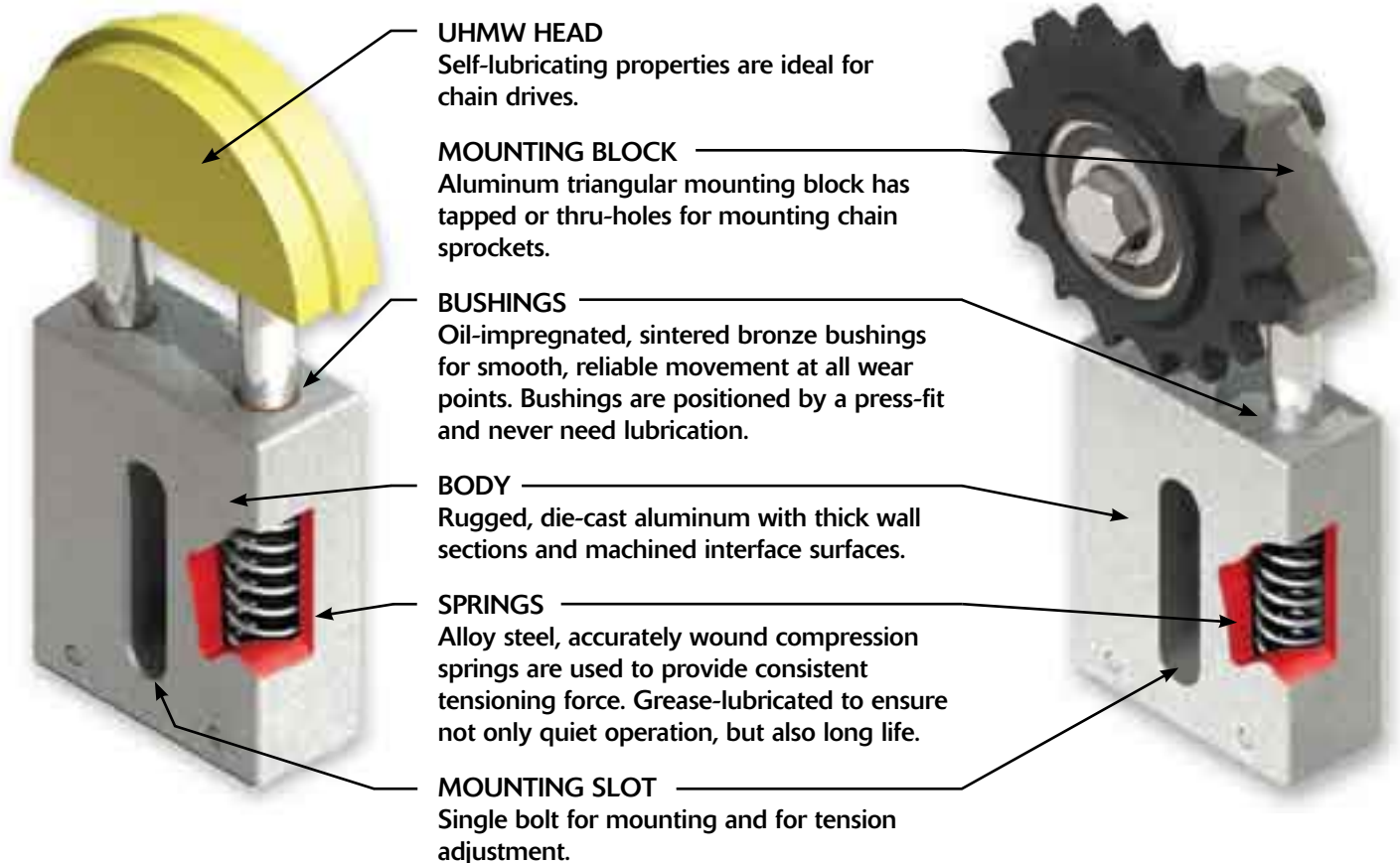

- Die-cast aluminum construction
- Easy installation and adjustment with single bolt feature
- Wide variety of sizes and mounting styles
- Improved performance and extended life for most fixed-center drives
- Built-in spring mechanism absorbs momentary overloads and reduces vibration
- Constructed from high-quality materials for proven durability
- Can be used in a host of industrial applications
- Fully automatic straight-line take up
- For harsh environments, contact Applications Engineering
- LT Series is ideal for use with PowerMax™ Idler Sprockets

CT Series

CT1100, CT2100 & CT3100

- Large arc-shaped head guides the roller chain
- Head made from UHMW — its self-lubricating properties are ideal for chain drives
- Spring forces up to 200 lbs (890 N).

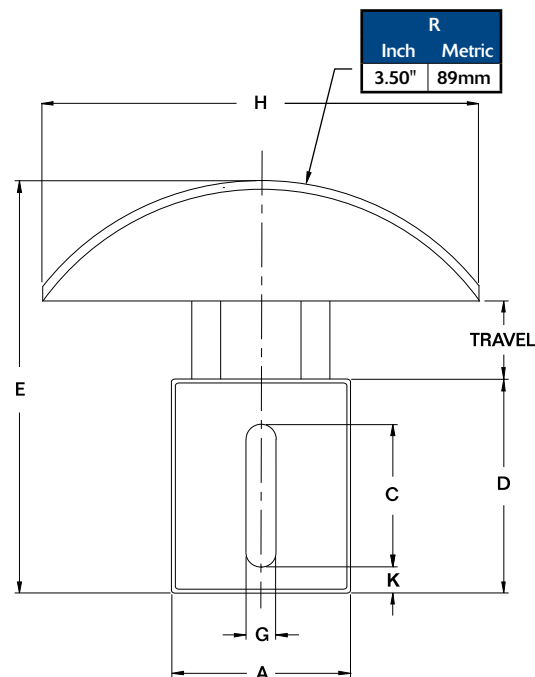
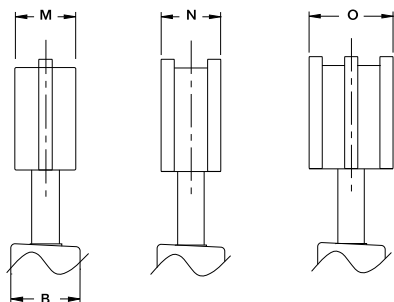

CT Series	Travel (inches)	Force ⁽³⁾ (lbs.)	CT Series	Travel (mm)	Force ⁽³⁾ (N)
1100-L	1.10	5 - 30	1100-L	28	22 - 133
1100	0.85	15 - 40	1100	22	67 - 178
2100	1.25	20 - 60	2100	32	89 - 267
3100	1.65	45 - 100	3100	42	200 - 445
3100-H	0.98	30 - 200	3100-H	25	134 - 890
3196	1.65	45 - 100			

Common Dimensions

	Series	A	B	C	D	E	G	H	K
Inch	CT1100	2.31	0.98	1.80	2.91	5.52	0.42	5.50	0.42
	CT2100	2.95	1.18	2.36	3.52	6.51	0.49	5.50	0.43
	CT3100	3.54	1.38	2.95	4.25	7.60	0.57	5.50	0.43
Metric	CT1100	59	25	46	74	140	11	140	11
	CT2100	75	30	60	89	164	12	140	11
	CT3100	90	35	75	108	193	14	140	11

Single Chain

Double Chain

Triple Chain

	Part No.	Chain	M	Part No.	Chain	N	Part No.	Chain	O
Inch	CT1101-L	#35	0.79	CT1103-L	#35	0.63	CT1105-L	#35	1.02
	CT1101	#35	0.79	CT1103	#35	0.63	CT1105	#35	1.02
	CT1102	#40	0.79	CT1104	#40	0.81	CT1106	#40	1.36
	CT2101	#50	0.87	CT2103	#50	0.98	CT2105	#50	1.63
	CT2102	#60	0.87	CT2104	#60	1.37			
	CT3101	#80	0.98	CT3103	#80	1.81			
	CT3102	#100	0.98						
	CT3102-H	#100	0.98						
	CT3196	#81X	1.75						
Metric	CT1111-L	06B	20	CT1113-L	06B	20			
	CT1111	06B	20	CT1113	06B	20			
	CT1112	08B	20	CT1114	08B	22			
	CT2111	10B	22	CT2112	10B	25			
	CT2109	12B	22	CT2110	12B	35			
	CT3111	16B	25	CT3113	16B	44			
	CT3112	20B	25						
CT3112-H	20B	25							

Notes

- 1) Inch dimensions are in inches; metric dimensions are in millimeters. These tensioners can be used on chain sizes up to ANSI #160 or BS/DIN #24B (see tensioner selection chart on page 15).
- 2) Contact Fenner Drives Applications Engineering group for head dimensions.
- 3) All forces are nominal.

CT Series

CT1200, CT2200 & CT3200

- Small arc-shaped head for use when space is limited
- Head made from UHMW — its self-lubricating properties are ideal for chain drives
- Spring forces up to 200 lbs (890 N).

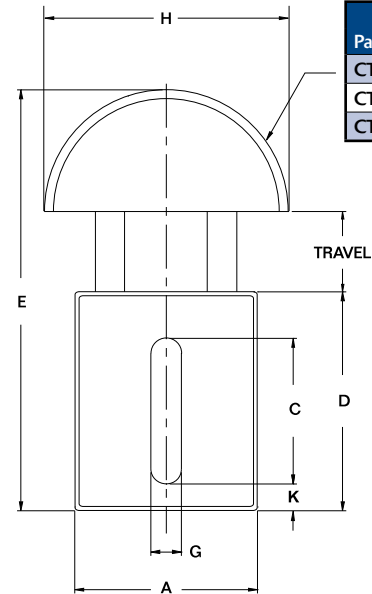
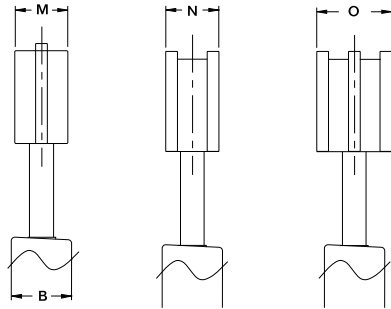

CT Series	Travel (inches)	Force ⁽³⁾ (lbs.)	CT Series	Travel (mm)	Force ⁽³⁾ (N)
1200-L	1.10	5 - 30	1200-L	28	22 - 133
1200	0.85	15 - 40	1200	22	67 - 178
2200	1.25	20 - 60	2200	32	89 - 267
3200	1.65	45 - 100	3200	42	200 - 445
3200-H	0.98	30 - 200	3200-H	25	134 - 890

Common Dimensions

	Series	A	B	C	D	E	G	H	K
Inch	CT1200	2.31	0.98	1.80	2.91	5.52	0.42	3.00	0.42
	CT2200	2.95	1.18	2.36	3.52	6.51	0.49	3.50	0.43
	CT3200	3.54	1.38	2.95	4.25	7.60	0.57	4.00	0.43
Metric	CT1200	59	25	46	74	140	11	76	11
	CT2200	75	30	60	89	164	12	89	11
	CT3200	90	35	75	108	193	14	102	11

	Single Chain			Double Chain			Triple Chain		
	Part No.	Chain	M	Part No.	Chain	N	Part No.	Chain	O
Inch	CT1201-L	#35	0.79	CT1203-L	#35	0.63	CT1205-L	#35	1.02
	CT1201	#35	0.79	CT1203	#35	0.63	CT1205	#35	1.02
	CT1202	#40	0.79	CT1204	#40	0.81	CT1206	#40	1.36
	CT2201	#50	0.87	CT2203	#50	0.98	CT2205	#50	1.75
	CT2202	#60	0.87	CT2204	#60	1.37			
	CT3201	#80	0.98	CT3203	#80	1.81			
	CT3202	#100	0.98						
	CT3202-H	#100	0.98						
Metric	CT1211-L	06B	20	CT1213-L	06B	20			
	CT1211	06B	20	CT1213	06B	20			
	CT1212	08B	20	CT1214	08B	22			
	CT2208	10B	22	CT2209	10B	25			
	CT2206	12B	22	CT2207	12B	35			
	CT3211	16B	25	CT3213	16B	44			
	CT3212	20B	25						
	CT3212-H	20B	25						

Notes

- 1) Inch dimensions are in inches; metric dimensions are in millimeters.
- 2) These tensioners can be used on chain sizes up to ANSI #160 or BS/DIN #24B (see tensioner selection chart on page 15). Contact Fenner Drives Applications Engineering group for head dimensions.
- 3) All forces are nominal.

CT Series

CT1400, CT2400, & CT3400 Fixed

- An economical tensioner for use when automatic tensioning is not required
- Slotted frame for quick and precise adjustment in any direction
- Head made from UHMW — its self-lubricating properties are ideal for chain drives
- For single and double chain applications

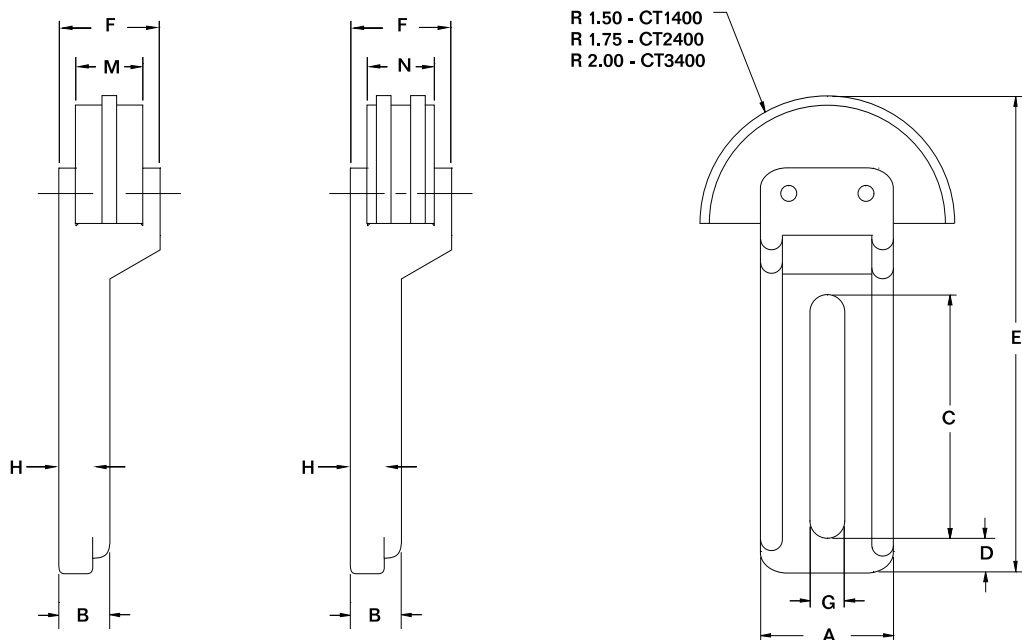

Part No.	A	B	C	D	E	F	G	H	M	N	Chain
CT1401	1.56	0.59	2.87	0.39	5.60	1.18	0.41	0.39	0.79	—	#35
CT1402	1.56	0.59	2.87	0.39	5.60	1.18	0.41	0.39	—	0.79	#35
CT1403	1.56	0.59	2.87	0.39	5.60	1.18	0.41	0.39	0.79	—	#40
CT1404	1.56	0.59	2.87	0.39	5.60	1.18	0.41	0.39	—	0.95	#40
CT2401	1.97	0.71	3.35	0.47	6.50	1.42	0.51	0.47	0.86	—	#50
CT2402	1.97	0.71	3.35	0.47	6.50	1.42	0.51	0.47	—	1.11	#50
CT2403	1.97	0.71	3.35	0.47	6.50	1.42	0.51	0.47	0.86	—	#60
CT2404	1.97	0.71	3.35	0.47	6.50	1.42	0.51	0.47	—	1.53	#60
CT2405	1.97	0.71	3.35	0.47	6.50	1.42	0.51	0.47	0.86	—	12B
CT2406	1.97	0.71	3.35	0.47	6.50	1.42	0.51	0.47	—	1.18	12B
CT3401	2.36	0.77	3.23	0.51	6.68	1.57	0.51	0.55	0.98	—	#80
CT3402	2.36	0.77	3.23	0.51	6.68	1.57	0.51	0.55	—	1.98	#80

Note All dimensions are in inches.

LT Series

LT1000, LT2000, & LT3000

- Ideal for use with Fenner Drives Roller Chain Idler Sprockets
- Spring forces up to 200 lbs.

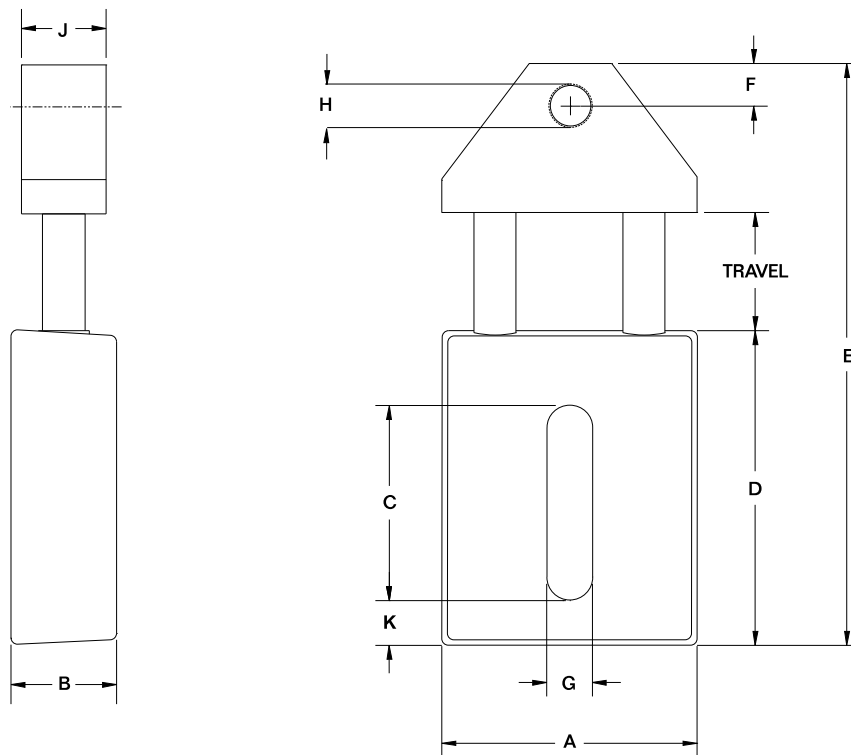

Part No.	A	B	C	D	E	F	G	H	J	K	Travel (inches)	Force ⁽³⁾ (lbs.)
LT1001-L	2.31	0.98	1.80	2.91	5.52	0.39	0.42	$\frac{3}{8}$ - 16	0.79	0.42	1.10	5 - 30
LT1001	2.31	0.98	1.80	2.91	5.52	0.39	0.42	$\frac{3}{8}$ - 16	0.79	0.42	0.85	15 - 40
LT1002	2.31	0.98	1.80	2.91	5.52	0.39	0.42	0.40	0.79	0.42	0.85	15 - 40
LT2001	2.95	1.18	2.36	3.54	6.81	0.47	0.49	$\frac{1}{2}$ - 13	0.98	0.43	1.25	20 - 60
LT2002	2.95	1.18	2.36	3.54	6.81	0.47	0.49	0.51	0.98	0.43	1.25	20 - 60
LT3001	3.54	1.38	2.95	4.25	8.27	0.55	0.57	$\frac{1}{2}$ - 13	1.18	0.43	1.65	45 - 100
LT3002	3.54	1.38	2.95	4.25	8.27	0.55	0.57	0.51	1.18	0.43	1.65	45 - 100
LT3002-H	3.54	1.38	2.95	4.25	8.27	0.55	0.57	0.51	1.18	0.43	0.98	30 - 200

- Notes
- 1) All dimensions are in inches.
 - 2) Maximum load no more than 1" distance from front face of tensioner to centerline of idler – see page 17.
 - 3) All forces (lbs.) are nominal.



Tensioner Selection Chart for Roller Chain Drives

Rotary & Linear Tensioners Single Chain

Model Series	ANSI BS/DIN	Chain Size								
		#35 06B	#40 08B	#50 10B	#60 12B	#80 16B	#100 20B	#120 24B	#140 —	#160 —
RT1600-L		X	X	X						
RT1600		X	X	X	X	X				
RT1000		X	X	X	X	X				
RT3000					X	X	X			
RT4100							X	X	X	
RT4900							X	X	X	
LT/CT1000-L		X	X	X						
LT/CT1000		X	X	X	X	X	X			
LT/CT2000				X	X	X	X			
LT/CT3000						X	X	X	X	
LT/CT3000-H							X	X	X	X

Rotary & Linear Tensioners Double Chain

Model Series	ANSI BS/DIN	Chain Size								
		#35 06B	#40 08B	#50 10B	#60 12B	#80 16B	#100 20B	#120 24B	#140 —	#160 —
RT1600-L		X	X							
RT1600		X	X	X	X					
RT1000		X	X	X	X					
RT3000					X	X	X			
RT4100						X	X			
RT4900						X	X			
LT/CT1000-L		X	X							
LT/CT1000		X	X	X	X	X				
LT/CT2000				X	X	X				
LT/CT3000						X	X			
LT/CT3000-H							X	X	X	X

PowerMax™ Pulleys & Sprockets

PULLEYS & IDLERS

Fenner Drives offers a wide range of metallic and non-metallic idlers for use with V-, flat and synchronous belts, and ANSI standard pitch roller chain sprockets. Listed below are some of the more frequently used sizes. For a complete product offering with dimensional data, visit our website www.fennerdrives.com. In addition, Fenner Drives has extensive custom capabilities and would be happy to design a solution for your application.

For elevated operating temperatures, contact Applications Engineering.

V-belt Idler Pulleys

Part No.	Recommended Shoulder Bushing		Type	Grooves	Belt Section	Dimensions	
	3/8" Bore	1/2" Bore				Dia.	Width
VA3001	SB0001	SB0004	1	1	A	3.00	0.70
VA4001	SB0001	SB0004	1	1	A	4.00	0.70
VA5001	SB0001	SB0004	1	1	B	5.04	0.80
VA6250	SB0001	SB0004	1	1	A/B	6.25	0.95
V2B6280	N/A	N/A	2	2	B/5V	6.28	1.72
V3B6280	N/A	N/A	2	3	B/5V	6.28	2.44

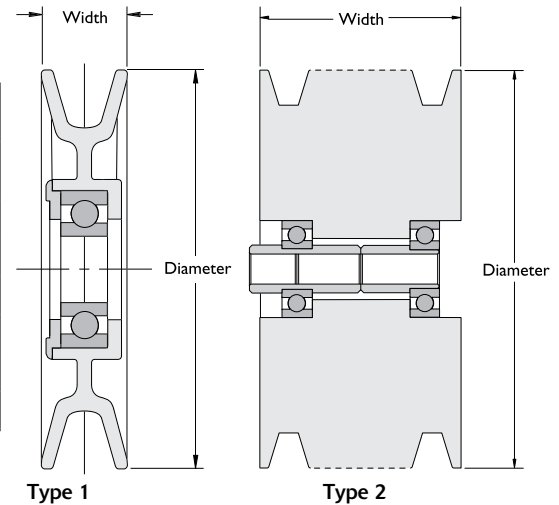

Flat Belt Idler Pulleys

Part No.	Recommended Shoulder Bushing		Type	Belt Size	Dimensions	
	3/8" Bore	1/2" Bore			Dia.	Width
FA2750	SB0002	SB0005	1	1.00	1.97	1.09
FA3002	SB0002	SB0005	1	1.00	2.50	1.02
FA3502	SB0002	SB0005	1	1.00	3.00	1.00
FA4501	SB0002	SB0005	1	1.00	4.00	1.09
FA5501	SB0002	SB0005	1	1.00	5.03	1.02
F1B6280	N/A	N/A	2	1.00	6.00	1.22
F2B6280	N/A	N/A	2	2.00	6.00	2.10
F3B6280	N/A	N/A	2	2.75	6.00	2.91

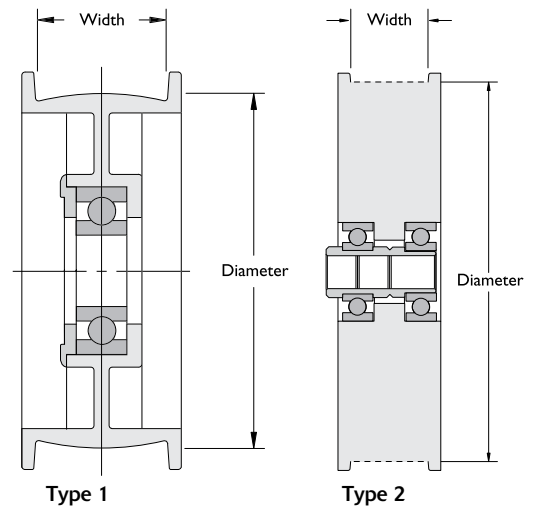

Chain Idler Sprockets

Part No.	Recommended Shoulder Bushing		Chain No.	No. Teeth	Dimensions	
	3/8" Bore	1/2" Bore			Dia.	Width
CS3502	SB0001	SB0004	35	19	2.48	.67
CS4002	SB0001	SB0004	40	17	2.98	.67
CS5002	SB0001	SB0004	50	15	3.36	.67
CS6002	SB0001	SB0004	60	13	3.49	.67
CS8002	SB0001	SB0004	80	12	4.40	.67

Note All dimensions are in inches.

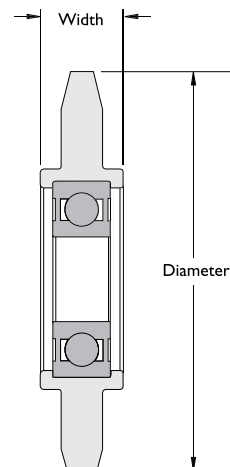

Overhung Load Information

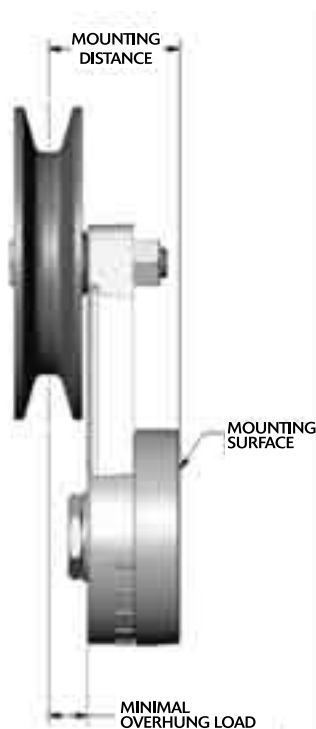

IDEAL APPLICATION

Fig. 1

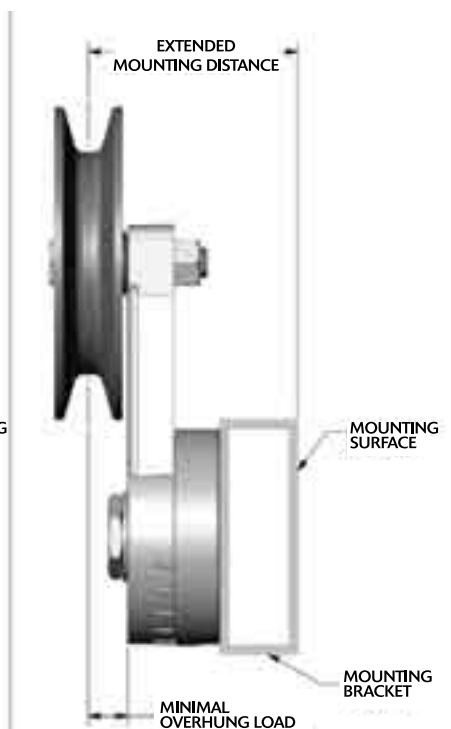

RECOMMENDED FOR
EXTENDED MOUNTING DISTANCES

Fig. 2

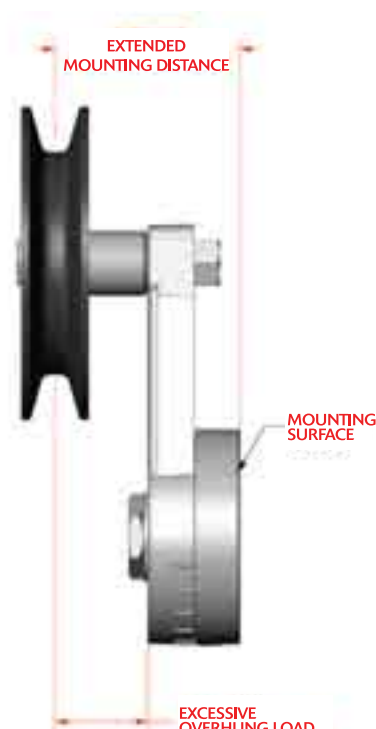

NOT RECOMMENDED FOR
EXTENDED MOUNTING DISTANCES

Fig. 3

Correct

To receive a full measure of performance from the tensioner/idler assembly, it is important to keep overhung loads to a minimum. Fig. 1 illustrates a properly designed tensioner/idler assembly where the overhung load is located close to the tensioner arm.

Overhung load is directly related to the tensioner mounting location. When considering a tensioner/idler assembly, the idler should be mounted close to the tensioner arm and then the tensioner/idler assembly positioned on the mounting surface. In some instances it may be necessary to fabricate a new mounting bracket or add plates, spacers, channel, etc. to the existing mounting surface to position the assembly allowing for correct alignment of the idler with the driveR and driveN components as illustrated in Fig. 2.

Incorrect

Although it is easy to move the idler further away from the tensioner arm to achieve correct alignment with the driveR and driveN, this is NOT the correct thing to do. Fig. 3 illustrates a poorly designed tensioner/idler assembly. Note the distance from the idler to the tensioner is excessive. This arrangement will introduce excessive load on the idler mounting bolt, tensioner arm and the tensioner body. The result will be poor performance and premature failure of the tensioner.

For specific dimension requirements, please refer to the specification pages in this catalog. If in doubt, contact Fenner Drives Applications Engineering group at ae@fennerdrives.com or 1-800-243-3374.

Application Examples

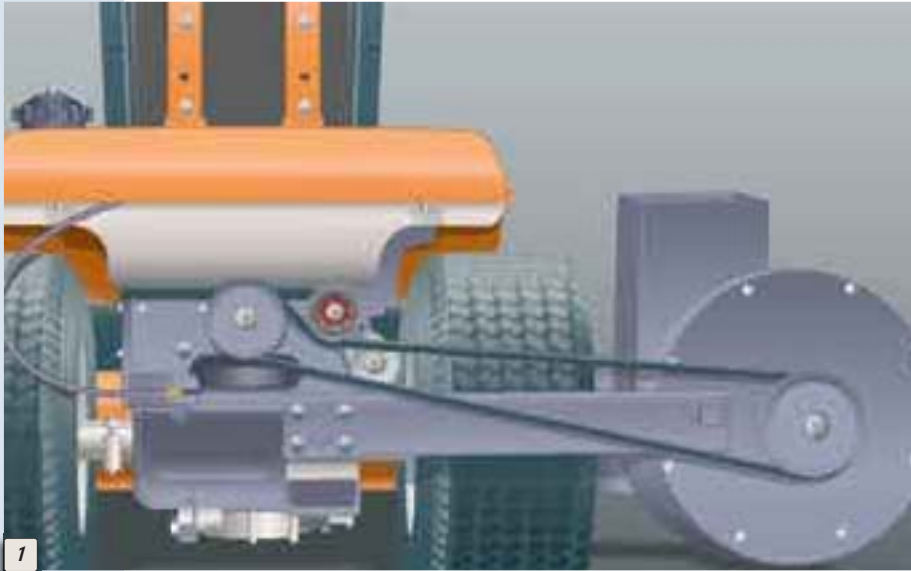

1



2



3



4

Illustrations by Mick Hill



5



6

1 Lawn and Garden This RT1003 rotary tensioner is used to maintain correct V-belt tension on the drive from the tractor PTO shaft to the vacuum blower shaft.

4 Agriculture This liquid sprayer uses an RT1003 to maintain correct chain tension and eliminate extra chain slack on this near vertical design.

2 Air Handling Using an RT4100 on a rotary screw compressor's multiple V-belt drive increases drive efficiency.

5 Building Maintenance Using an RT3001 on a floor scrubber/polisher ensures correct V-belt tension on this non-adjustable fixed center drive.

3 Lumber Processing CT2200 series Linear Chain Tensioner takes up the cantenary chain sag on drives with long spans.

6 Agriculture T-Max RT1003 automatically keeps this agricultural V-belt drive tensioned and running efficiently in all weather conditions.

Frequently Asked Questions

When should I use a rotary versus linear tensioner?

A linear moves in a straight line and a rotary swings in an arc. Sometimes mounting location, drive configuration, etc., will not permit the use of one versus the other. The application should be closely reviewed to determine which tensioner is best suited.

Which tensioner is the best one for my application?

Generally, the rotary style is primarily used on belt drives, although it can also be used with chain drives. The CT linear tensioner with the UHMW head is the most popular on chain drives. We can help you determine which is best for your application — just give us a call.

Can I use the tensioner/idler on the backside of a belt?

Yes. Although a backside idler increases wrap angle and power transmission capacity, it does introduce a reverse or back bend in the belt that will shorten belt life. Consult with the belt manufacturer for minimum pulley diameter and location.

My drive reverses — where do I position the tensioner/idler?

Spring-loaded tensioners should never be used on reversing drives. If they are, when the drive reverses the slack side becomes the tight side and vice versa. A tensioner designed for the slack side would then have inadequate spring force to maintain belt tension.

How do I determine what size tensioner/idler I need for my belt drive?

Selection of the proper size tensioner can be made using the guidelines specified in this catalog. Consult with the belt manufacturer, who can determine the right amount of spring force based on the application and drive parameters.

I have some contaminants in my application — will they have any effect on the tensioner?

Our tensioners are made from die-cast aluminum and coated steel. Although many chemicals/oils will not affect them, they are not resistant to all. Contact Fenner Drives Applications Engineering group with the contaminants present and we'll make a recommendation.

Where is the best place on my V-belt drive to locate a tensioner/idler?

Preferably, a tensioner/idler should be located on the inside and slack side of the drive. Optimum placement would be where it provides nearly equal arcs of contact on both the driveR and driveN pulleys.

Where do I position the tensioner on my chain drive?

The tensioner should be located on the slack or sag side of the chain and outside the perimeter of the chain strand.

Where should I position the tensioner in the chain span?

Unless a chain guide is being used, the tensioner should be located an equal distance from the driveR and driveN sprockets.

My chain drive appears to have excessive slack — will a tensioner help this problem?

Usually, under normal conditions chain slack should not exceed 4% of the span. For unusual conditions such as heavy loads, frequent starts/stops, etc. it should not exceed 2% of the span. Excessive chain slack usually occurs on drives with long spans. Typically a span greater than 50P (P = chain pitch) will require a tensioner.

I am using chain other than standard ANSI or BS/DIN roller chain. Can I get the UHMW head on a CT linear tensioner to match my chain?

Consult Fenner Drives Applications Engineering group. We have been able to design and furnish many special UHMW heads.

Do I need to periodically grease the springs?

In most cases, no. The RT3000 series and RT4000 series do not require any lubrication pre- or post-assembly. For all other series, the springs are pre-lubricated at the factory when the unit is permanently assembled. However, on occasion an application may dictate the need for re-lubrication. Contact Fenner Drives Applications Engineering group. We may be able to design a tensioner with a fitting that will allow this.

Count on Fenner Drives.

We've got the right product for your application.



EAGLE
POLYURETHANE BELTING & O-RINGS

PowerTwist Plus
V-BELTS

SUPER T LINK
SP WEDGE BELTS

NU T LINK
V-BELTS

T-MAX
BELT & CHAIN TENSIONERS

PowerMax
PULLEYS & IDLERS

B-LOC
KEYLESS BUSHINGS

Trantorque
Keyless Bushings

Trackstar
UHMW BELT & CHAIN GUIDES

Fenner Drives is a proven leader in the design and manufacture of problem-solving power transmission and motion transfer components. Recognized widely for our expertise and innovation in manufacturing technology, we consistently blend reliability, quality and value in our products. As part of our commitment to provide unsurpassed technical support and service, we maintain extensive engineering, development and testing facilities. Fenner Drives has three manufacturing plants across two continents.

Products are available globally with sales and support offices in Leeds, UK and Manheim, USA.

Visit us at www.fennerdrives.com

 **Fenner Drives**
an ISO 9001 certified company

311 West Stiegel Street
Manheim, PA 17545-1747

www.fennerdrives.com
TEL: 800-243-3374
TEL: 717-665-2421
FAX: 717-665-2649

Hudson Road
Leeds, LS9 7DF UK

www.fennerdrives.com
TEL: +44 (0)870 7577007
TEL: +44 (0)113 2493486
FAX: +44 (0)113 2489656

Information subject to change without prior notification.
Visit www.fennerdrives.com/catalogs for the most current information.